

## The Infrared Beamline at the Australian Synchrotron

Mark Tobin,<sup>1</sup> Dudley Creagh,<sup>2</sup> Don McNaughton,<sup>3</sup> Jonathan McKinlay,<sup>1</sup> Andy Broadbent<sup>1</sup>

1. Australian Synchrotron, 2. University of Canberra, 3. Monash University

The infrared beamline at the Australian Synchrotron has been designed to extract 58 (h) x 22 (v) milliradians of radiation from sector two of the storage ring. This large horizontal aperture will allow extraction of both bending magnet and edge radiation from a single aperture, which will be directed to two instruments at the endstation. A Bruker IFS-125 high resolution FTIR spectrometer will receive the edge radiation portion of the beam, while the bending magnet section of the beam will be directed to a Bruker V80v FTIR spectrometer and Hyperion 2000 IR microscope. The beamline is being designed, manufactured and assembled by FMB GmbH with optics supplied by Kugler GmbH (M1), SESO (focusing optics) and OK – Optikkomponenten und Kristalle GmbH (plane mirrors).



M1 mirror insertion mechanism



M1 mirror front face

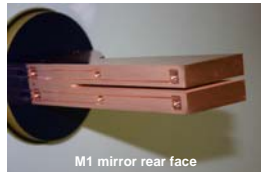

M1 mirror rear face

Extraction of the infrared beam from the synchrotron dipole vacuum chamber is achieved using a slotted plane mirror (M1) which is inserted horizontally through a flange in the side of the dipole vessel. The mirror insertion mechanism and completed M1 mirror are shown above. The upper photograph of M1 shows the gold coated reflective front face, and the lower photograph shows the location of the thermocouple fixing points on the rear of the mirror. After being reflected out of the dipole vessel by M1, the infrared beam is then refocused by a toroidal mirror M2 and steered through the concrete shield wall of the synchrotron by two plane mirrors M3 and M3a. These mirrors are shown in an expanded view to the right hand side of the illustration below.

External to the shield wall, the infrared beam passes through a wedged CVD diamond window, which separates the UHV section of the beamline from the HV section downstream of the window. A periscope unit raises the horizontal height of the beam before it enters a set of beamsplitting optics. This separates the expanding beam into two, one part predominantly edge radiation, the other predominantly bending magnet radiation. At this point the two beams are also refocused towards two independent secondary focal points.

The separated beams are each directed, under vacuum, to two matching optics boxes. These vessels contain collimating mirrors designed to deliver a parallel beam of infrared radiation closely matched to the acceptance aperture of the two instruments. In the case of the high resolution spectrometer this is set to 65mm, whereas for the microscope this can be altered from 10mm up to 20mm through the selection of alternative collimating mirrors. The mirrors will also include motors to allow adjustment of the angle, height and lateral position of the merging collimated beam.

The beamline and FTIR instrumentation will be located in a self contained laboratory on the synchrotron experimental floor. This will have separate working areas for the high resolution IR instrument and the FTIR microscope, and will provide separate rooms for sample preparation and for off-line analysis of users' data.



Bruker IFS 125 high resolution FTIR

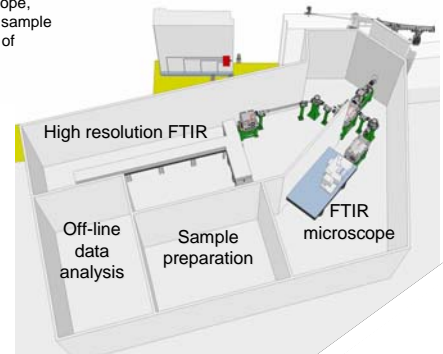

The sample preparation area will be equipped with a stereo microscope with dark and light field transillumination, plus fiberoptic top illumination for mounting of samples. Desiccated sample storage equipment will also be available. The off-line data analysis area will be equipped with two PCs operating the Bruker FTIR software, plus Thermo GRAMS Version 8, and Cytospec multivariate spectral imaging software.



Bruker Hyperion 2000 infrared microscope

The infrared facilities at the Australian Synchrotron will be tailored to the needs of the research community and future developments will be made in response to those need. Likely additions to the beamline include the upgrade of the IR microscope with a focal plane array detector, the installation of a high pressure diamond anvil cell and the development of environmental chambers for in-situ infrared studies of living organisms. It is also expected that a long pathlength gas cell would be added to the high resolution FTIR system.

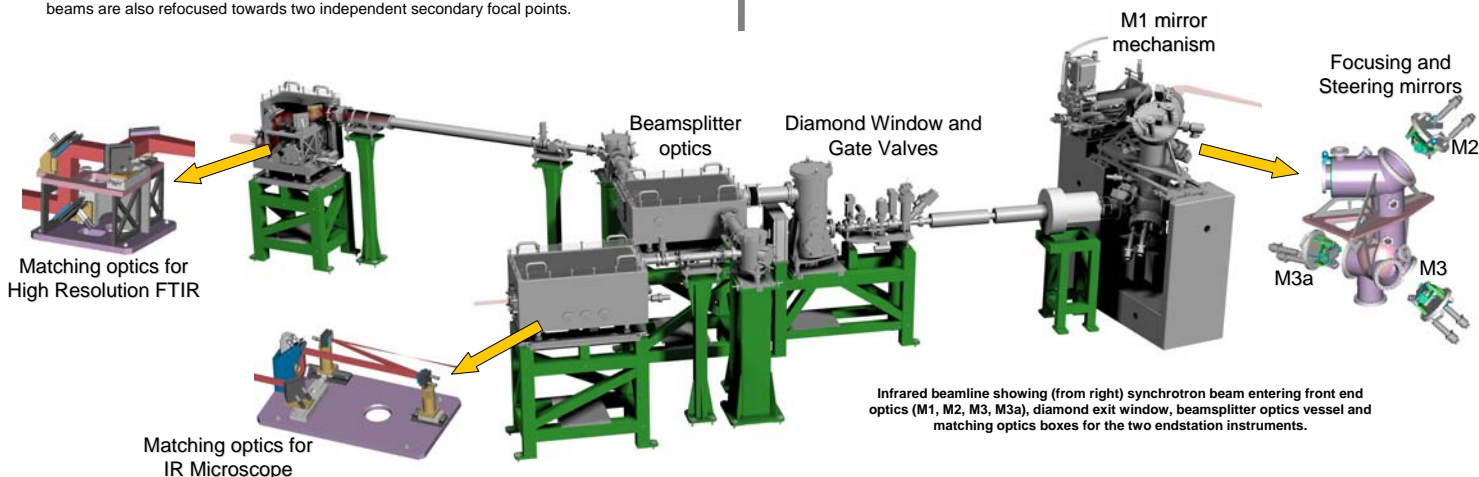

Infrared beamline showing (from right) synchrotron beam entering front end optics (M1, M2, M3, M3a), diamond exit window, beamsplitter optics vessel and matching optics boxes for the two endstation instruments.